

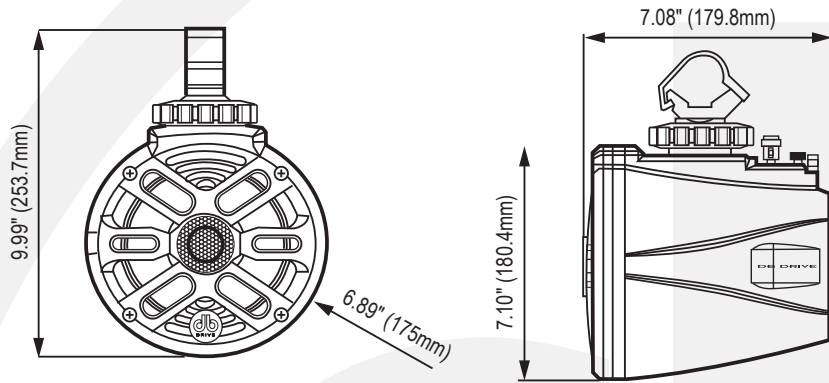

English



APT65RGB

- **Power Handling : 90 Watts RMS**
- **Max Power Handling : 180 Watts**
- **4Ω : Frequency Response : 45Hz - 20KHz**
- 2-Way wakeboard tower speaker enclosure with RGB LED accent lighting
- Marine and power sports grade element proofing technologies.
- 6.5" UV protected 2-way loud speaker with grill mounted aluminum dome tweeter.
- Ultra compact high strength Polyethylene enclosure with UV inhibitors and stainless steel assembly hardware.
- 360° Rotational easy adjust swivel mounting brackets compatible with 1.5", 1.75, 1.85" and 2.00' roll cages.
- Integrated RGB LED accent lighting (RGBC-8 or RGBC-4RF module required - sold separately).
- Marine grade compression speaker terminals.
- Developed for Marine and Power Sports outdoor applications.



LIMITED WARRANTY

DB Drive™ warrants any products purchased in the U.S.A. from an authorized DB Drive™ dealer. All products are warranted to be free from defects in material and workmanship under normal use and service for a period of one year.

DB Drive™ will either repair or replace (as its option) any unit that has been found to be defective and under warranty provided the defect occurs within the warranty period.

One (1) year if purchased through an authorized DB Drive™ dealer.

This limited warranty does not extend to units that have been subjected to misuse, abuse, neglect, or accident. Products that in DB Drive™'s judgment show evidence of having been altered, modified, or serviced without DB Drive™'s authorization, will be ineligible under this warranty.

To obtain warranty service please contact your retailer or see our website www.dbdrive.net for more details.



MARINE / POWER SPORTS TOWER SPEAKERS

MODEL #

APT65RGB

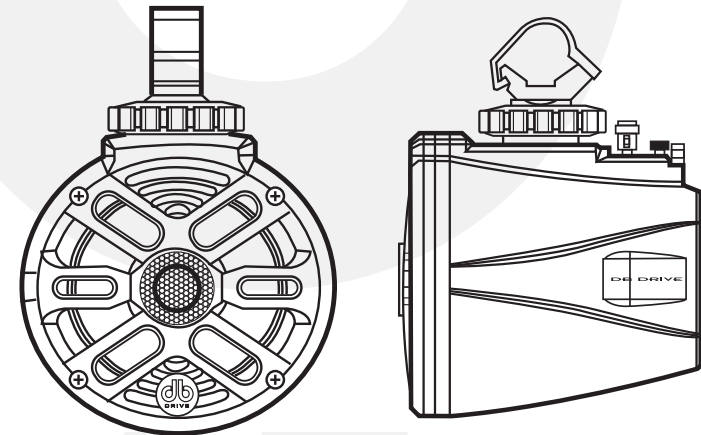

Installation Instructions / Owner's Manual



DB Research L.L.P. ■ 302 Hanmore Industrial Parkway ■ Harlingen, TX 78550
Ph: (877) 787-0101 ■ Fax: (956) 421-4513 ■ tech support: support@dbdrive.net