

PCAM-810-AHD



## Side View AHD Camera with Night Vision User Manual



## Introduction

Thank you for purchasing your EchoMaster Pro automotive camera.

EchoMaster cameras are designed to improve safety during driving by providing high quality images of surrounding areas and obstacles in the vicinity of the vehicle. They will also improve vehicle maneuvering capability by displaying blind spots not normally visible to the driver.

Please ensure you read and understand all aspects of this manual before fitting or using your EchoMaster Camera. Choose a suitable mounting place dependent on the application. Ensure that there are no wiring harnesses or hoses/pipes located behind this panel before drilling.

## Key Features

- ▶ 1/3" CMOS Analog High Definition (AHD) Sensor
- ▶ Operates at 0.1 LUX
- ▶ 6 IR LEDs
- ▶ IP69 Rated
- ▶ 150 Degree Diagonal Viewing Angle
- ▶ CVBS/AHD Video Format Output

## Specifications

PCAM-810-AHD	
Sensor Type	1/3" CMOS AHD
LEDs	6
Illumination	0.1 LUX
Viewing Angle (Diagonal)	150 degrees
Mirror Image (Selectable)	YES
Parking Lines	NO
Water/Debris-Proof	IP69
Audio	NO
Power Supply	9V-12V DC
Current	<125mA
Working Temperature	-20°C - +70°C
Resolution	1280 x 720
System	NTSC AHD
TV Lines	720P
Dimensions W x D x H	55 x 62 x 43 mm 2.16 x 2.44 x 1.7 in

## Box Contents

- ▶ Camera
- ▶ Hardware / Allen Wrench
- ▶ Mounting Template
- ▶ User Manual
- ▶ Warranty Card

## Dimensions

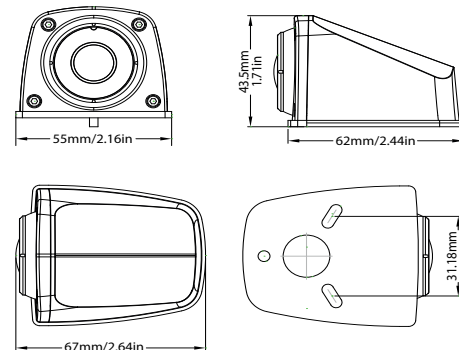

NOTE: To adjust camera direction/angle, loosen 4 allen bolts, adjust, re-tighten allen bolts.

## Wiring Diagram & Pin Out

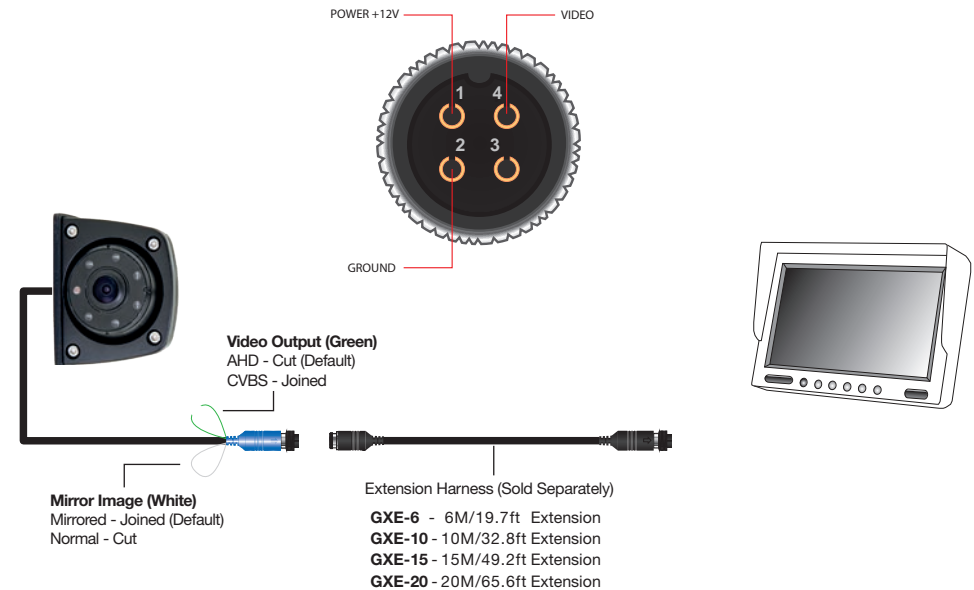

REV. 091619

EchoMaster.com

EchoMaster is a Power Brand of AAMP Global



email - support@aampglobal.com (US)  
 tel - 866-931-8021

