

MNT-BOX 2

Outdoor Junction Box



- Aesthetic design
- Material: Aluminum & SECC
- Fits MNT-ARM, PTZ WALL ARMS, MNT-POLIP, MNT-PCNRIP.
- Includes (4) M6x25 screws, (4) M6x14 screws, (4) M8 Plastic anchors, (3) Water joint, (1) Wrench

Technical Specification

Model	MNT-BOX 2
Physical Properties	
Material	Aluminum & SECC
Dimension(W xH xD)	11.69"x9.76"x4.17" (297mmx248mmx106mm)
Weight	3.2kg (7.05lb)
Load Bearing	8.0kg (17.64lb)
Color	White
Operating Temperature	40°C~60°C(-40°F~140°F)
Humidity	0~90% RH
Inch Thread	M20(G1/2")
Applicable Models:	MNT-ARM, PTZ WALL ARMS, MNT-POLIP, MNT-PCNRIP.

Dimensions (mm/in)

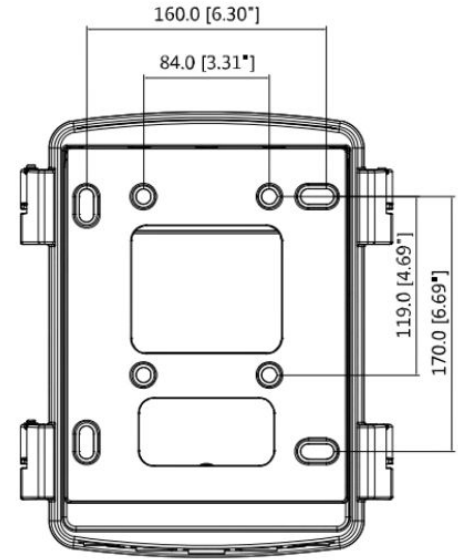
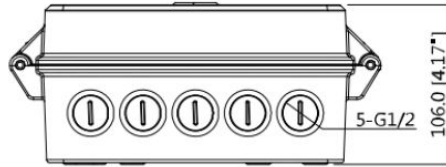
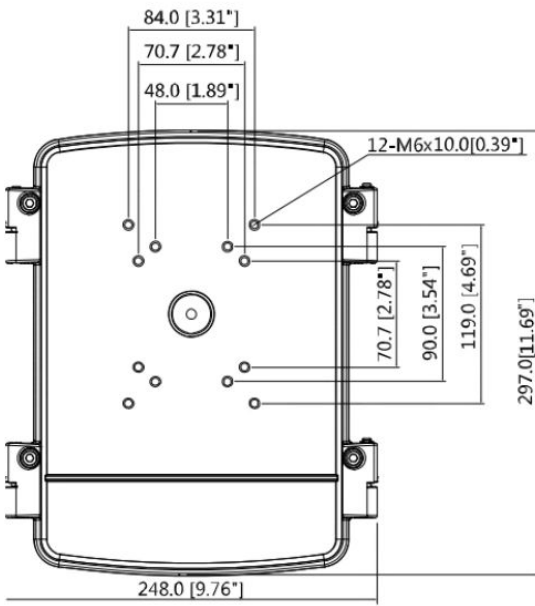

Application

