



# NU-GM51

Navigation Unlock Interface for GM Vehicles equipped with the MyLink/CUE Audio System

## Introduction & Features

The NU-GM51 is a Navigation Unlock interface that allows the factory navigation and Bluetooth features of your 8" MyLink/CUE Radio to be used by the passenger at anytime.

## Important Notes

1. Vehicle must be in the **OFF** position when disconnecting the radio brain and installing the NU-GM51 harness/module.
2. When installing the NU-GM51 into the ATS or the CTS Sedan it will require you do disconnect the HVAC module. This is a small black module with 4 connectors found in the passenger kick panel. Please be sure the vehicle is off when disconnecting this module and make sure that when reconnecting, **the Brown connector is connected LAST**. Failure to connect the Brown connector last will trigger a DTC and put the A/C into limp mode. A trip to the dealership to have it reset will be needed in the event these instructions are not followed.
3. The NU-GM51 Activation menu will not be displayed when the OnStar is being used.

## Installation

\*\*\*Check the chart below for the location of the radio brain in your vehicle.\*\*\*

Disconnect the Grey 20-pin harness from the vehicles radio brain. Connect the male 20-Pin connector of the NU-GM51 harness into the 20-pin port on the vehicles radio brain. Connect the factory 20-Pin harness into the female connector on the NU-GM51 harness. Connect the black 24-pin micro-fit connector of the NU-GM51 harness into the NU-GM51.

Year	Make	Model	Radio Brain location
2015	Chevrolet	Colorado	Behind the touch panel display for the radio.
2015	Chevrolet	Corvette	Under passenger side dash, behind carpet, towards firewall. Attached to plastic BCM bracket.
2015	Chevrolet	Impala	Under passenger side dash, behind the glove box behind plastic underdash panel.
2015	Chevrolet	Silverado	Behind the touch panel display for the radio.
2015	Chevrolet	Suburban	Behind A/C controls in dash
2015	Chevrolet	Tahoe	Behind A/C controls in dash
2015	GMC	Canyon	Behind the touch panel display for the radio.
2015	GMC	Sierra	Behind the touch panel display for the radio.
2015	Cadillac	ATS	Under passenger side dash, behind the glove box behind plastic underdash panel.
2015	Cadillac	CTS	Under passenger side dash, behind the glove box behind plastic underdash panel.
2015	Cadillac	XTS	Under passenger side dash, behind the glove box behind plastic underdash panel.
2015	Cadillac	SRX	Under passenger side dash, behind the glove box behind plastic underdash panel.
2015	Cadillac	Escalade	Behind the touch panel display for the radio.

## Module Overview

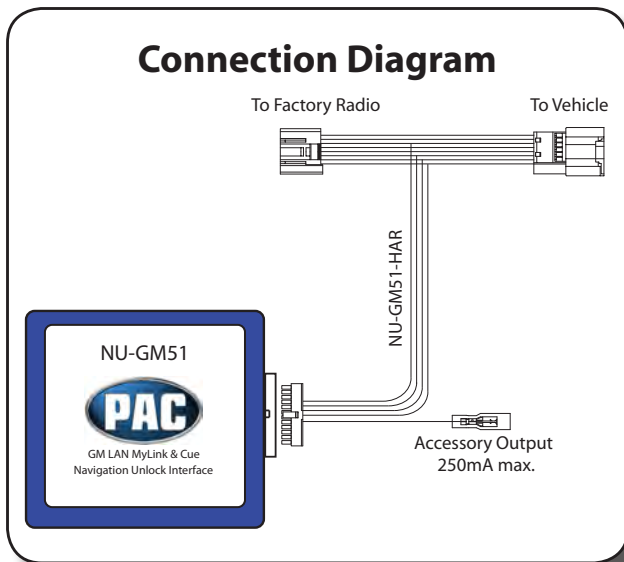

## Radio Brain Overview

Below is what the radio brain looks like. It will house the AM/FM and Satellite antennas for reference.

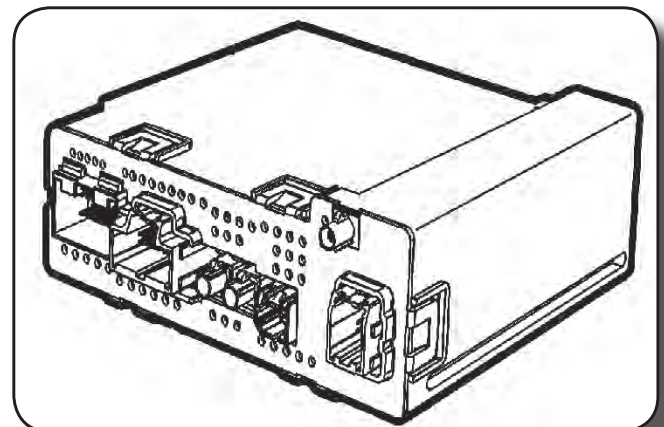



## Operation

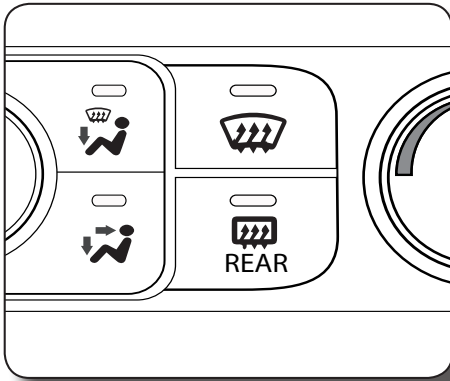

FIG A.

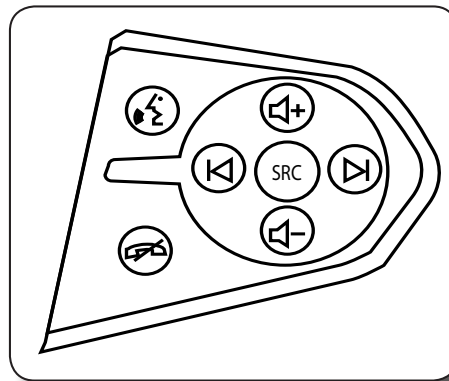

FIG B.

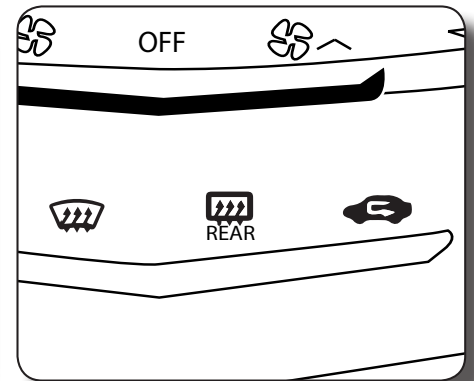

FIG C.

## Activating the Navigation Unlock

### In Chevrolet & GMC vehicles with the MyLink Audio systems (excluding Colorado):

Press the rear defrost button (Fig. A) twice on the HVAC panel to activate the NU-GM51. You will hear one chime and the radio's display will prompt you with the "Confirm Off-road Use" menu. Press the "Accept" button on the radio's display to acknowledge "Off-road use", agreeing that use will be performed off-road or only by the passenger whenever the vehicle is in motion, and activate the NU-GM51. Two chimes will be heard once the NU-GM51 has been successfully activated. To de-activate the NU-GM51 simply press the rear defrost button twice on the HVAC panel. Three chimes will be heard when the NU-GM51 module has been de-activated.

### In Chevrolet Colorado:

Press and hold the SRC button on the steering wheel controls (Fig B.) for 2 seconds to activate the NU-GM51. You will hear one chime and the radio's display will prompt you with the "Confirm Off-road Use" menu. Press the "Accept" button on the radio's display to acknowledge "Off-road use", agreeing that use will be performed off-road or only by the passenger whenever the vehicle is in motion, and activate the NU-GM51. Two chimes will be heard once the NU-GM51 has been successfully activated. To de-activate the NU-GM51 simply press and hold the "SRC" button on the steering wheel controls for two seconds. Three chimes will be heard when the NU-GM51 module has been de-activated.

### In Cadillac vehicles with the CUE Audio systems:

Press the rear defrost button (Fig. C) twice on the HVAC panel to activate the NU-GM51. You will hear one chime and the radio's display will prompt you with the "Confirm Off-road Use" menu. Press the "Accept" button on the radio's display to acknowledge "Off-road use", agreeing that use will be performed off-road or only by the passenger whenever the vehicle is in motion, and activate the NU-GM51. Two chimes will be heard once the NU-GM51 has been successfully activated. To de-activate the NU-GM51 simply press the rear defrost button twice on the HVAC panel. Three chimes will be heard when the NU-GM51 module has been de-activated.

**WARNING:** In order to avoid distraction, which could lead to an accident, the driver should never utilize systems unlocked by the NU-GM51 when the vehicle is in motion. Even when operated by the passenger, the vehicle driver should maintain their attention on the road at all times.

DISCLAIMER: Under no circumstances shall the manufacture or the distributors of the NU-GM51 be held liable for claims of any loss or damage, consequential, direct or indirect, arising from the sale, installation, or use of the NU-GM51. The manufacture and its distributors will not, nor will they authorize any representative or any other individual, to assume obligation or liability in relation to the NU-GM51 other than its replacement.

AGREEMENT: End user agrees to use this product in compliance with the instructions and terms of use above and with all State and Federal laws. PAC provides instructions and safety warnings with respect to this product and disclaims all liability for any use not in conformity with those instructions or other misuse of its product. If you do not agree, please discontinue use immediately and return product to place of purchase. This product is intended for off-road use and passenger use only.

