

Overview

The RPK4-GM2301 is a complete radio replacement kit with vehicle information retention for select 11-Bit GMLAN Vehicles. This kit utilizes a user friendly LCD display with onboard buttons to view and adjust vehicle information and settings. The included radio replacement interface will retain factory steering wheel controls (SWC) and allows you to program two radio functions to each SWC button by using short press long press dual command functionality. The interface also provides data bus driven outputs such as retained accessory power (RAP), illumination, vehicle speed sensor (VSS), reverse trigger and parking brake.

Table of Contents:	Page:
1. Factory Radio Removal -----	2
2. Radio Replacement Installation and Wiring Instructions -----	3
3. Steering Wheel Control Programming -----	3-4
4. Dash Kit Assembly -----	5
5. Using the PAC-LCD -----	6

Parts List

The RPK4-GM2301 includes everything you need for a professional installation of an aftermarket radio in your 11-Bit GM Vehicle.

This kit contains:

1. Dash kit
 - 1a. (x1) Double DIN mounting panel
 - 1b. (x1) Single DIN radio ISO mount trim ring
 - 1c. (x1) LCD adapter bracket (for single DIN applications)
 - 1d. (x1) Pocket (for single DIN applications)
 - 1e. (x8) Radio mounting screws
 - 1f. (x1) USB cover (for when USBDMA1 or USBDMA6 is not used with our kit)
 - 1g. (x2) Radio mounting brackets (one left and one right)
2. Radio replacement interface module
3. Radio connection harnesses
4. PAC-LCD

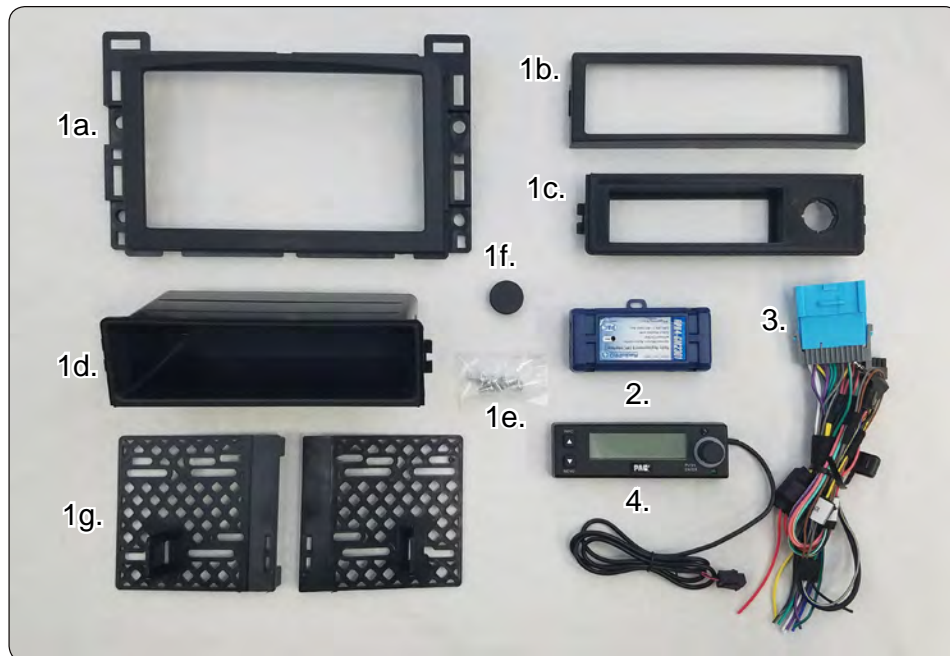

Important Notes

1. If a double DIN radio is being installed with this kit, enough wire has been supplied to mount the LCD in the glove box or center console area.
2. The interface comes pre-programmed for all of the vehicle's factory SWC functions and does not require programming, unless you wish to re-assign the SWC functions, or utilize short press long press dual command functionality. The SWC can always be restored to default settings by pressing and releasing the program button on the side of the interface once and waiting 7 seconds for the LED to flash 3 times.
3. The LED will flash whenever a SWC button is pressed.
4. The Interface has the ability to retain the warning chimes and audible turn signal clicks through its onboard piezo. This feature is on by default. This can be disabled using the supplied PAC-LCD. For more info on disabling the chimes through the module see page 6.



Removing the factory radio from the vehicle

2004 - 2007 Chevrolet Malibu / Malibu Max / 2008 Chevrolet Malibu Classic

1. Carefully unclip the thin side trims from both the left and right side of the radio trim bezel.
2. Remove the (2) 9/32 screws from below the driver side under-dash panel.
3. Unclip and remove the side edge panel from the left side of the dash.
4. Remove the (2) 9/32 screws securing the left side of the driver side under-dash panel.
5. Unclip the wire harness from the side trim of the driver's side under-dash panel.
6. Using a panel removal tool, carefully pry downward on the panel at the bottom of the driver's side under-dash panel. (There are (3) panel clips).
7. Using a panel removal tool, unclip the top edge of the driver's side lower dash panel and lower out of the way.
8. Lower the glove box door all the way down.
9. Remove the single 9/32 screw from the middle of the glove box door latch bar.
10. Remove the (4) 9/32 screws securing the glove box dash section to the sub-dash.
11. Carefully remove the side panel from the right side of the dash.
12. Repeat steps 4 and 5 above for the right side of the dash.
13. Unclip and lower the panel below the glove box and remove the single 9/32 screw from the lower left side of the glove box panel.
Remove the glove box and panel.
14. Starting from the bottom of the radio/HVAC control trim bezel, pull bezel outward to unfasten.
15. Disconnect the hazard harness from the radio/climate control bezel and remove bezel.
16. Loosen the (2) 9/32 screws securing the HVAC controls.
17. Remove the (4) 9/32 screws securing the radio to the sub-dash.
18. Carefully pull radio upward and outward, disconnect the wire harness and antenna lead to remove radio.

2005 - 2006 Chevrolet Cobalt

1. Carefully pop the trim above the glove box with a panel removal tool. Remove trim at the top left of dash bezel.
2. Remove the dash panel with a panel removal tool. Note: Dash panel clips are very tight.
3. Disconnect the wire harness behind dash panel.
4. Remove the (4) 9/32 screws securing the radio to the sub-dash.
5. Carefully pull the radio upward and outward, disconnect the wire harness and antenna lead to remove radio.

2005 - 2009 Pontiac G6

1. Remove side trim panels from both driver and passenger side dash with a panel removal tool.
2. Remove (2) 9/32 screws on both driver and passenger side dash.
3. Remove (3) 9/32 screws from under steering column panel. Remove and set aside.
4. Remove (9) 9/32 screws which hold the glove box assembly in place. Lower the glove box and set aside.
5. Gently remove dash assembly from around radio, unclipping 1 plug located between the vents. Remove (4) 9/32 bolts securing the radio in place.
6. Remove (2) 9/32 bolts securing heater control assembly in place. Slide the HVAC control assembly forward and remove the factory radio.

Illustration / Schematic

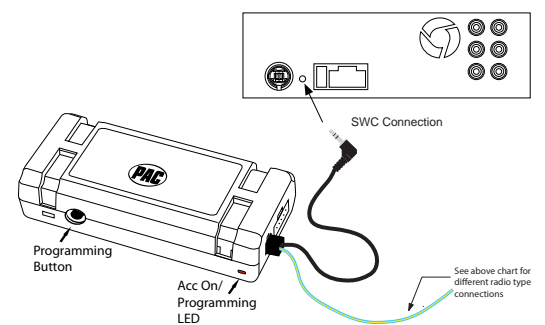
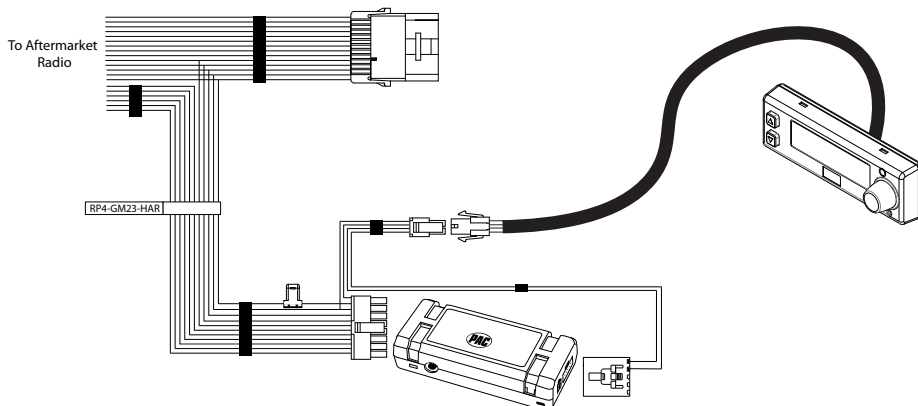

Configuration and Wiring of Interface

SET RADIO SELECT SWITCH



Alpine	JVC	Kenwood	Clarion	Pioneer/Other	Sony	Fusion
1	2	3	4	7	8	9

Other = Advent, BOYO, Dual, Lightning Audio, Rockford Fosgate, Visteon

1. The radio select rotary switch on the side of the interface must be adjusted to the proper radio setting before plugging the interface into the vehicle.
2. Make all connections as described in the chart below.
3. Connect the SWC wire or jack according to the chart below (aftermarket radio MUST support a wired remote input).
4. If you wish to reassign functions to the steering wheel controls, follow the optional programming instructions on the next page.

Aftermarket Radio Connections

Vehicle Connector

Yellow	Battery +12v
Black	Ground
White	Front Left + input
White / Black	Front Left - input
Grey	Front Right + input
Grey / Black	Front Right - input
Green	Rear Left + input
Green / Black	Rear Left - input

Vehicle Connector

Purple	Rear Right + input
Purple / Black	Rear Right - input
Blue*	Amp / Antenna Turn On

Interface Connector

Red	Accessory +12v Output
Orange / White	Illumination Output (+)
Pink**	Vehicle Speed Output
Purple / White**	Reverse Output (+)
Light Green**	Parking Brake Output (-)

SWC Connector

Blue / Yellow (SWC Output)	Kenwood or Newer JVC
3.5mm Jack (SWC) Output	Alpine, JVC, Clarion, Pioneer, Sony, Boyo, Dual, Lightning Audio, Visteon, Jensen or Advent

* Blue wire must be connected even if the vehicle is not equipped with an amplifier. Connect to the aftermarket radios Blue / White remote turn on wire.

** These connections are not necessary when installing a single DIN head unit.

Default Steering Wheel Control Programming

IMPORTANT! The interface comes pre-programmed for the functions listed in the chart below and does not require programming unless you wish to re-assign the SWC functions to different buttons. The SWC can always be restored to default settings by pressing the program button on the side of the interface once and waiting for the timeout. **PLEASE NOTE: Due to the many different possible OEM SWC configurations, some applications may need to be reprogrammed for the SWC assignments to match the button on the wheel.**

Default SWC Button Assignments

	Alpine	JVC	Kenwood	Clarion	Pioneer	Sony	Fusion
Volume +	Volume +	Volume +	Volume +	Volume +	Volume +	Volume +	Volume +
Volume -	Volume -	Volume -	Volume -	Volume -	Volume -	Volume -	Volume -
Seek Up	Track +	Track +	Track +	Search +	Track +	Track +	Track +
Seek Down	Track -	Track -	Track -	Search -	Track -	Track -	Track -
Band	Band / Program	Band / Disc+	N / P	Band	Band	Band	N / P
1-6	Preset +	Preset / Disc -	Disc / FM +	N / P	Preset +	Preset +	Power
Source	Source	Source	Source	Source	Source	Source	Source
Mute	Mute	Mute	Mute	Mute	Mute	Mute	Mute

Optional Steering Wheel Control Programming

If you wish to re-assign the SWC functions or utilize short press long press dual command functionality, the interface must be programmed in the specific order shown on the chart on the next page. If you come across a function in the chart that your steering wheel does not have, or you do not want to program, press and release the programming button on the side of the interface to skip that function. The LED will flash off and on confirming that you have successfully skipped that function and are ready to proceed to the next one.

Short Press Long Press Dual Command Functionality

This feature allows you to assign two aftermarket radio functions to each of the vehicle's SWC buttons. It can be used with as many of the buttons as the user likes or none at all. When this functionality is implemented, quickly pressing and releasing a SWC button will initiate the short press command, while pressing and holding a SWC button for longer than two seconds will initiate the long press command. Please note that no long press commands are programmed by default. If you wish to assign dual command functionality to the SWC please follow the programming steps on the next page.



Optional Steering Wheel Control Programming (cont.)

Programming

- Turn the key to the ignition position.
- Press and release the programming button on the side of the interface.
- Within 7 seconds, press the button that is to be learned on the steering wheel. The LED will turn off when the button is pressed.
At this point you have two options:
 - For short press functionality:** Release the button within 1.5 seconds. The LED will turn back on.
 - For long press functionality:** Hold the button until the LED starts blinking. Release the button and the LED will go back to solid.
- If you need to program more buttons, repeat step 3 for each additional audio function on the steering wheel.
- If you come across a function in the chart that your steering wheel does not have, or you do not want to program, press and release the program button on the side of the interface to skip that function.
- Once programming is completed, wait seven seconds. The LED will flash three times indicating end of programming.
- Test the interface for proper functionality. Whenever a SWC is pressed the LED on the interface should blink. If any function does not work, repeat the programming steps.

Optional Programming Order

	Alpine	JVC	Kenwood	Clarion	Other *	Pioneer	Sony	Fusion
1	Volume +	Volume +	Volume +	Volume +	Volume +	Volume +	Volume +	Volume +
2	Volume -	Volume -	Volume -	Volume -	Volume -	Volume -	Volume -	Volume -
3	Mute	Mute	Mute	Mute	Mute	Mute	Mute	Mute
4	Preset +	Source	Source	Source	Preset +	Preset +	Preset +	Source
5	Preset -	Track +	Play	Search +	Preset -	Preset -	Preset -	Track +
6	Source	Track -	Track +	Search -	Source	Source	Source / End Call	Track -
7	Track +	Band / Disc +	Track -	Band	Track +	Track +	Track +	Audio
8	Track -	Preset / Disc -	Disc / FM +	Send / End	Track -	Track -	Track -	Power
9	Power	Select	Disc / AM -	Send	Band	Band	Band	
10	Enter / Play	Attenuation	Answer	End	Answer **	Phone Menu	Power / End Call	
11	Band / Program	Phone Receive	Voice Dial	VR	End **	Answer Call	Voice Dial / Answer / End Call	
12	Receive	Phone Reject	On Hook		PTT **	End Call	VR (Android Auto & Car Play) Answer / End Call***	
13	End	Voice Dial	Off Hook			VR		
14	VR	Power	Mute					
15			Preset +					

* Advent, Boyo, Dual, Lightning Audio, Jensen, Rockford Fosgate & Visteon ** Jensen & Advent ONLY *** XAV-AX100 Only

Steering Wheel Control Re-calibration

SWC re-calibration is necessary when the SWC operation is erratic or non-existent. This process re-calibrates the SWC values to the RPK4 interface for button function assignment. The interface must be programmed in the specific order shown in the table below. If you come across a function in the chart that your steering wheel does not have you must press and release the program button on the side of the interface to skip that function. The LED will flash off and on confirming that you have successfully skipped that function and are ready to proceed to the next one.

The SWC and radio command assignments can always be restored to default values by entering re-calibration mode (Steps 1-3) and not pressing any buttons. After 7 seconds the re-calibration mode will time out and all default values will be restored.

- Turn the key to the ignition position.
- Press and hold the programming button for 7 seconds until the LED begins blinking. When the LED begins blinking, release the programming button.
- Within 7 seconds, press and release the button that is to be learned on the steering wheel. The LED will turn off when the button is pressed and come back on when it is released.
- If you need to program more buttons, repeat step 3 for each additional audio function on the steering wheel.
- If you come across a function in the chart that your steering wheel does not have, press and release the program button on the side of the interface to skip that function.
- Once programming is completed, wait 7 seconds and the LED will flash three times indicating end of programming.
- Test the interface for proper functionality. Whenever a SWC is pressed the LED on the interface should blink. If any function does not work, repeat the programming steps.
- After you have re-calibrated the SWC buttons, the default SWC button assignments will be the same as what is listed in the chart on page 3. If you wish to re-assign button functions you must also go through the programming process in the section above.

Button Programming Order
Volume Up
Volume Down
Seek Up
Seek Down
Source
Mute
1-6
Band



Dash Kit Assembly

There are three configurations for installing this kit which will be covered in this section.

Double DIN

1. Remove the shaded area (A) from both the left and right mounting brackets (Only the left bracket is shown in Fig. A to the right). Next, if installing this kit into a Chevrolet Cobalt, remove the shaded areas (B) at the top of the mainframe.
2. Attach left and right mounting brackets to the kit as shown in Fig B.
3. Insert ISO mountable radio between ISO mount brackets and loosely attach to the sides of radio using screws provided with radio when possible, or screws supplied with kit.
4. Slide the radio forward or backward for desired look and tighten the screws.
5. Attach a rear support bracket to the rear of the new radio and adjust as necessary to support the weight of the radio (Optional).
6. Mount the PAC-LCD in the glove box or center console area using the supplied cable length.
7. Connect all necessary cables to the back of the radio and insert the dash kit and radio combo into the dash. Secure it using the (4) 9/32 screws removed during removal of the factory radio.

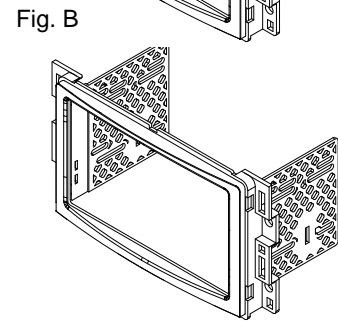
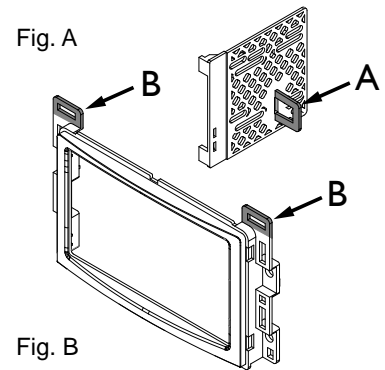

Single DIN with Pocket

1. If installing this kit into a Chevrolet Cobalt, remove the shaded areas (A) at the top of the mainframe.
2. Attach left and right mounting brackets to the kit as shown in Fig C.
3. Insert pocket into lower section of kit from the rear & lock into slots of mounting brackets as shown in Fig. C.
4. Insert ISO mountable radio between ISO mount brackets and loosely attach to sides of radio using screws provided with radio when possible, or screws supplied with kit.
5. Slide the radio forward or backward for desired look and tighten the screws.
6. Attach a rear support bracket to the rear of the new radio and adjust as necessary to support the weight of the radio (Optional).
7. Mount the PAC-LCD in the glove box or center console area using the supplied cable.
8. Connect all necessary cables to the back of the radio and insert the dash kit and radio combo into the dash and secure it using the (4) 9/32 screws removed during removal of the factory radio.

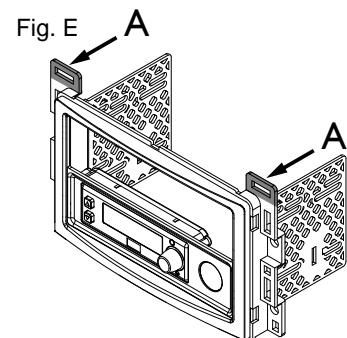
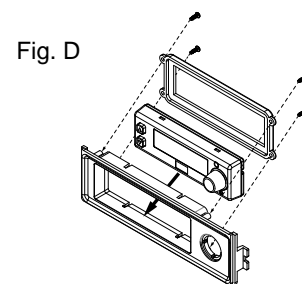
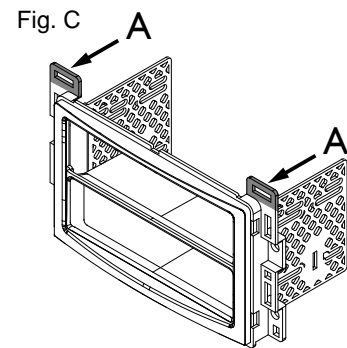

Single DIN with LCD adapter bracket

1. Slide the LCD into the adapter bracket from the rear and secure it using the supplied back plate and screws shown in Fig. D.
2. If installing this kit into a Chevrolet Cobalt, remove the shaded areas (A) at the top of the mainframe shown in Fig. E.
3. Attach left and right mounting brackets to the kit as shown in Fig E.
4. Insert LCD adapter bracket into lower section of kit from the rear & lock it into the slots of mounting brackets as shown in Fig. E.
5. Insert ISO mountable radio between ISO mount brackets and loosely attach to sides of radio using screws provided with radio when possible, or screws supplied with kit.
6. Slide the radio forward or backward for desired look and tighten the screws.
7. Attach a rear support bracket to the rear of the new radio and adjust as necessary to support the weight of the radio (Optional).
8. Connect all necessary cables to the back of the radio and insert the dash kit and radio combo into the dash and secure it using the (4) 9/32 screws removed during removal of the factory radio.

Using the PAC LCD to adjust the factory settings

With the addition of the PAC-LCD the user is able to retain the vehicle's settings and information that would normally be lost when the factory radio is replaced. The PAC-LCD buttons are labeled like the factory radio button, providing the user with a more factory like user experience. Pressing the Info button will allow you to cycle through the following vehicle information: Trip A, Trip B, Fuel Range, Econ, Average Speed and Oil Life. Pressing the Menu button or turning the rotary dial clockwise will allow you to cycle through the following vehicle settings: Oil Life Reset, Units, Lock Horn, Unlock Horn, Lights Flash, Delay Lock, Auto Unlock, Unlock, Exterior Lights, Security and Language. The Enter button can be used to change any of the settings while they are displayed on the screen. For additional information on the vehicle information or vehicle settings please consult the vehicle's owner's manual.

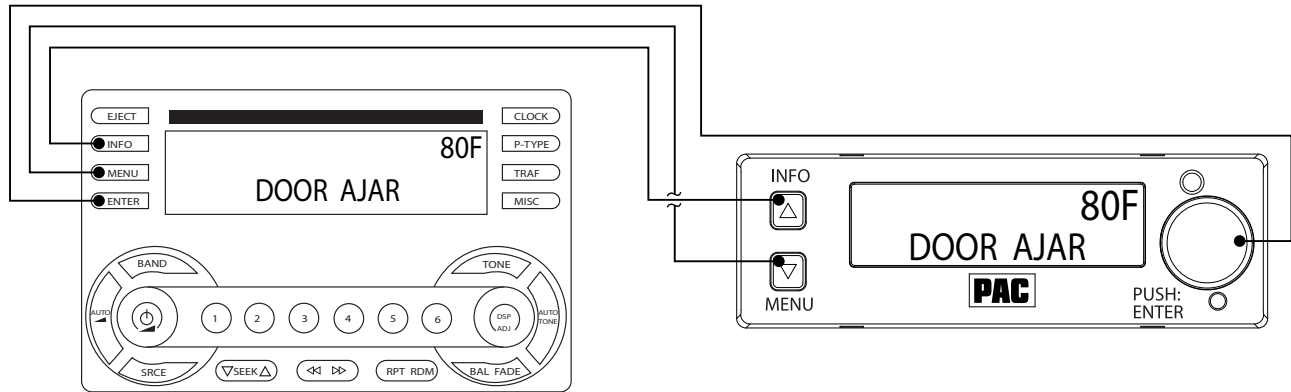

Setup Menu

The RPK4-GM2301 is equipped with a Setup Menu where the user can adjust the following settings:

Chimes: On or Off (*Module produces warning chimes. Not needed when the vehicle produces the chimes from the dash speaker*)

Chime Volume: High or Low (*Changes the level of the chimes heard from our module*)

Turn Signal Click: On or Off (*Module makes a ticking noise whenever the turn signal is on*)

Exit Menu

To access this menu, press and hold the INFO button on the PAC-LCD for 7 seconds. Once the display changes and "Chimes: On" is displayed you can release the INFO button. To advance to the next item in the setup menu, press the MENU button or turn the rotary dial to the right. To change any of the settings, press the ENTER button while it is displayed on the PAC-LCD. When finished, advance to the "Exit Setup" function and press the ENTER button.

Testing and Verification

1. Turn the ignition on. The LED on the interface will turn on and the +12v accessory wire will turn on.
2. Turn on the radio and check balance and fade.
3. Verify that all SWC are functioning properly.
4. Verify that the PAC-LCD is functioning properly.
5. Adjust the settings in the setup menu if necessary.
6. Turn off vehicle and remove key. RAP will be active and keep the radio on for 10 minutes or until the driver's door is opened.
7. The LED and radio will turn off when RAP turns off, or the driver door is opened.

Technical Support and Product Updates (Firmware)

The RPK4-GM2301 can be updated with new firmware as it becomes available using the PAC-UP interface updater (sold separately). Please visit www.PAC-audio.com/firmware for available updates.

Technical Support
support@PAC-audio.com
866-931-8021

