

Input Voltage	Max Power Draw	Fitment
12-15V DC	26W	5 Wheel Lug Pattern

Warranty and Disclaimer

Within THREE years after the purchase date, the original buyer may return any XKGLOW products that has one or more LEDs that fail to illuminate, due to a defect in materials or workmanship.

Installation of this product must be performed by a licensed professional. Should the failure of the product be the result of damage occurring as a result of improper installation, alteration of the product or an act or omission on the part of the consumer, this warranty is void. XKGLOW Lighting shall not be responsible for any consequential damages which arise from the use and/or installation of the product. If the kit is installed in any manner other than specified, XKGLOW Lighting reserves the right to deny any warranty claims at the discretion of the technical support department. Any product return must include the original packaging, invoice number and a statement of the alleged defect. Upon receipt of the returned product, the company will test the product for defect. If the results of the testing do not support the warranty claim, do not reveal any defect or indicate consumer negligence in the installation and handling of the product, then the product will be returned to you and you will be charged a reshipping fee. If the product is returned from an address within the continental United States, within the first 30 days after purchase, and is found to be defective, XKGLOW Lighting will exchange or refund the original purchase expense. This offer does not extend to the cost for shipping charges on any international packages.

Additional Disclaimer Terms

Please check your local and state laws for the proper use of this product.

- Improper installation of electrical products such as lighting may cause damage to any vehicle or device to which the improperly handled or installed lighting is attached.
- Improperly installed product may cause electrical injury to persons.
- Installation of this product must be performed by a licensed professional.
- XKGLOW assumes no liability for the installation of the product.
- Warranty or liability will not exceed the product purchase price, which shall be buyer's sole and exclusive remedy.
-

Return/Exchange Procedure

1. Email xk@xkglow.com to notify us of the product issue as well as the item number and name of customer on invoice.
2. We will send you the trouble-shooting guide to fix the issue, or to narrow down which of the component(s) need to be replaced. If the issue still exists, we will ask you to send back the defective items to be replaced.
3. Please send the returned item as instructed, along with claims and a telephone number where you can be reached.
4. After the returned item(s) have been accepted and inspected, we will issue a refund or replace the items ASAP. For refunds, item(s) must be sent to XKGLOW within 14 days from date of purchase. Original shipping charges are not refundable.

We always stand behind our products and are committed to our customers! For questions you may have, please contact xk@xkglow.com. We normally respond within 24 hours. (Monday-Friday).

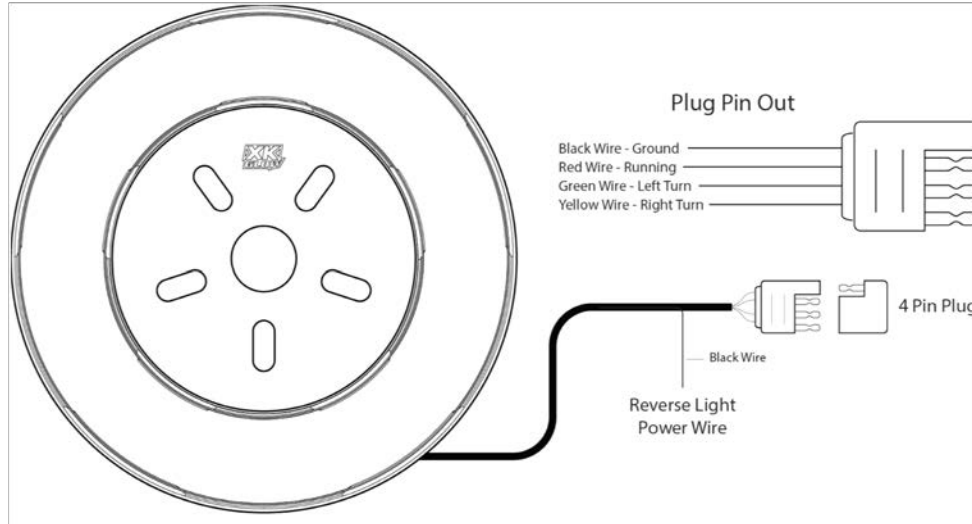

- 1. Test Wheel Light:** Before mounting, plug light bar into 4 pin trailer plug. With the vehicle off, turn on hazards and check operation.
- 2. Remove Spare Tire:** Carefully remove the spare tire from the back of your Jeep.

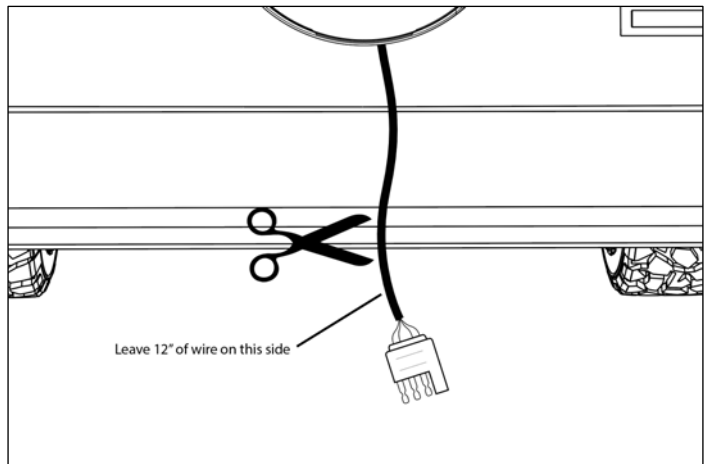
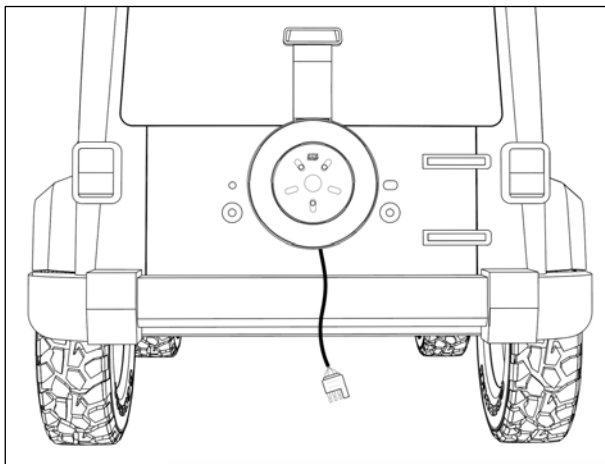

- 3. Position Wheel Light:** With the spare tire removed, place the wheel light onto the spare tire hub. To prepare routing the wiring, cut off the 4 pin plug. **If re-using the 4 pin plug, be sure to leave about 12" of wire on the plug end for crimping/soldering.**
- 4. Route Wiring into Tailgate:** Remove the grommet as shown below. Using a 1/4" drill bit, drill a hole in the center of the grommet. Feed the wiring through the drilled grommet and then insert the wiring and grommet into the hole on the tailgate.

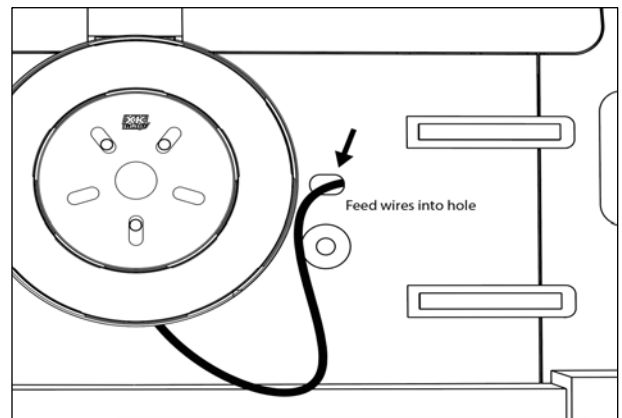
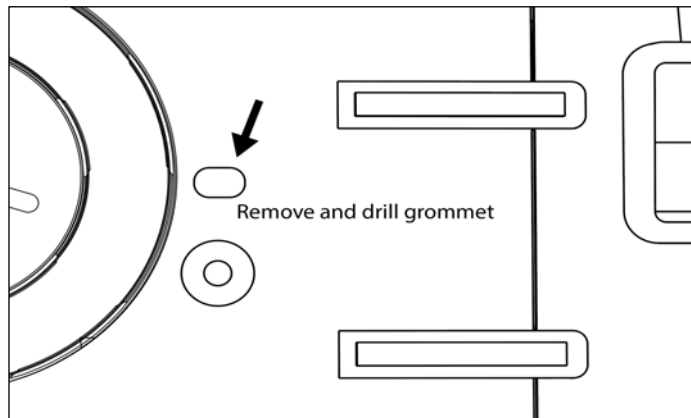

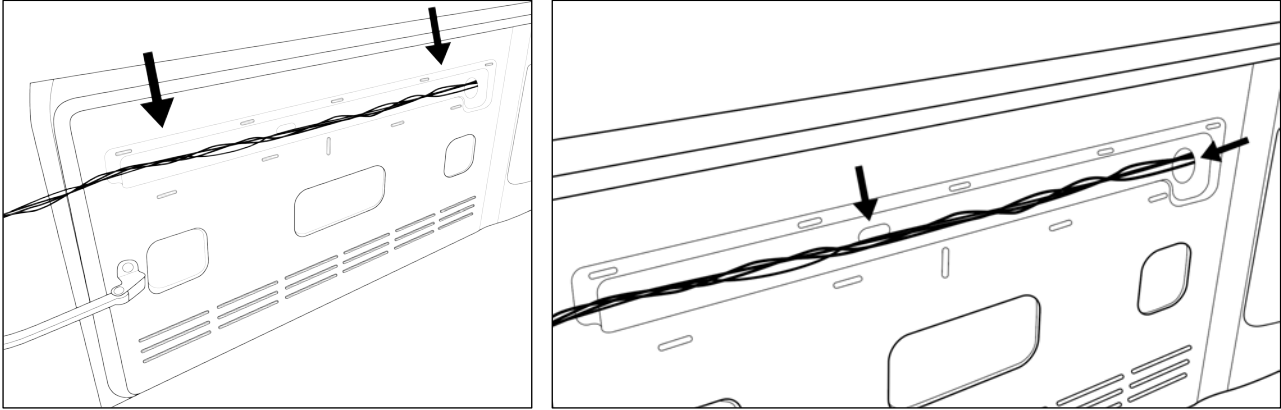

5. **Route Wiring out of Tailgate:** As shown above, remove the plastic trim piece to reveal factory wiring. Using a wire coat hanger, fish Wheel Light wiring through one of the holes shown on the right. Follow factory wiring into the Jeep. Secure wiring with zip ties and reinstall plastic cover.
6. **Reinstall Spare Tire:** Put the spare tire back on while keeping the Wheel Light centered. Torque lug nuts to factory spec.

Wiring Option 1 - Plug into 4 Pin Trailer Plug:

1. Using the supplied butt connectors, crimp the 4 pin plug back onto the wiring harness ensuring that the wire colors match.
2. Route 4 pin plug wiring down and out of the Jeep nearest the hinges on the right side of the vehicle. Drop plug down between the body of the Jeep and the bumper.
3. Plug the 4 pin plug on the Wheel Light into the 4 pin trailer plug on the truck.
4. Wire in reverse light. Using the supplied red scotchlok, tap the additional black wire into the factory reverse light positive wire behind the right side tail light. See service manual for vehicle's reverse + wire color.
5. Secure any loose wiring.
6. Power on vehicle and test functionality.

Wiring Option 2 - Hard Wire into Tail Lights:

1. Using the supplied scotchloks, tap the black, red, and yellow wire into its corresponding wire behind the **RIGHT** side tail light. See diagram on Page 1 for plug pinout.
2. The green wire will be tapped into the turn signal positive wire on the **LEFT** side of the vehicle. The included extension wire is to reach the left side of the vehicle. Use one of the scotchloks to extend the green wire and another scotchlok to tap into the left side turn signal positive wire. Route wiring under carpet or the plastic trim pieces at the bottom of the tail gate.
3. Wire in reverse light. Using the supplied red scotchlok, tap the additional black wire into the factory reverse light positive wire behind the right side tail light. See service manual for vehicle's reverse + wire color.
4. Secure any loose wiring.
5. Power on vehicle and test functionality.